

Marine aquariums



- Setup according to nature
- Successful maintenance

Contents

1. Tropic seas, an extremely diverse habitat	4
1.1 Live rock	5
1.2 Which animals are suitable?	5
2. Marine water biotope suggestions ...	11
2.1 Biotope: Clownfish, anemone	12
2.2 Biotope: Reef pool	15
2.3 Biotope: Gobies, pistol shrimps.....	18
3. Technical equipment and filtration ...	21
3.1 Compact aquariums for an easy start into the marine world	21
3.2 The optimal light	22
3.3 The correct water temperature	23
3.4 Water purification	24
4. The correct location	30
5. Sea salt: The basis for life in a marine aquarium	31
5.1 How to condition tap water	31
5.2 How to prepare marine water	32
5.3 How to measure salinity	32
6. Setup	33
6.1 Bottom gravel	33
6.2 Live rock	34
7. Filling in marine water	35
7.1 Starting filtration and technical equipment	35
7.2 Topping up water	35
8. Watch your aquarium come to life... 36	
8.1 The first days – “The activation phase”	36
8.2 How to introduce and acclimatize the animals	37
9. Regular maintenance	38
9.1 Feeding	38
9.2 Water changes	41
9.3 Supplying trace elements, calcium and macro elements	42
9.4 Monitoring and adjusting pH value, carbonate hardness and carbon dioxide	46
9.5 Monitoring ammonium, nitrite and nitrate	49
9.6 Checking the water	52
9.7 Cleaning the filter media	54
9.8 Removing excess algae	54
9.9 Removing deposits	54
9.10 Testing the lighting	54
10. When you are on a vacation	55
11. What to do in case an animal gets ill	56





Better life quality with an aquarium

A marine aquarium allows you to leave everyday routine behind. Dive into exotic water worlds, observe little adventures and dream of fascinating coral reefs or great beaches in the South Seas. This is like a holiday at home. Aquariums also support our health and joy of life. This has been proven by studies. You will simply feel better with an aquarium.

Marine aquariums look great and decorative. The light displays by water reflections and the organisms swaying in the currents are a unique pleasure – an optical highlight in every apartment.



Cushion star *Culcita novaeguineae* in a seaweed meadow near New Guinea

Ring shaped fringing reef in southeast Indonesia

1. Tropic seas, an extremely diverse habitat

The seacoasts near the equator are not only home to thousands of fish species but also to invertebrates whose number is not yet even known. The species diversity and the networks the species form in a tropical coral reef are as unbelievably complex as tropical rainforests and their inhabitants, and they are an inspiration for aquarists again and again.

Many of the species living in the shallow water of coral reefs, seaweed meadows or mangrove zones are excellently suitable for aquariums and can be kept without much effort. Their unbelievable colors and behavior make the animals, as well as the entire aquarium, a real eye-catcher.



1.1 Live rock

Live rock means reef rock chunks which are transported moist and at an appropriate temperature along with their entire plant and animal organisms growing on them. Many useful small organisms will get into your aquarium this way and support a natural environment.



before
introduction

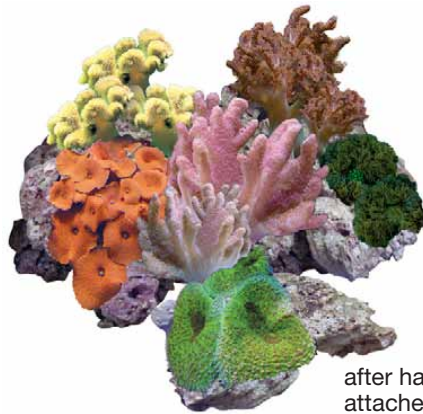

after having
attached corals

1.2 Which animals are suitable?

If corals, shrimps and other invertebrates are to be kept in the same aquarium, the variety of suitable fish is reduced. Many fish are predators that eat smaller fish, shrimps or coral tentacles.

However, even peaceful fish may cause problems: Seahorses, for example, have to

be fed very often which may cause water pollution. Also, they eat very slowly, resulting in other fish eating their food. Furthermore, they require calm water conditions and therefore cannot be kept in coral reef aquariums with strong currents.

Corals and other invertebrates

Some corals have algae, so-called zooxanthellae, living in their tissues. These corals need not be fed since they receive all required nutrients from the zooxanthellae. Other coral species, that do not get their nutrients from zooxanthellae, need to be fed.

Good water care provided, the invertebrates listed in the following are robust aquarium inhabitants:



e.g. Leather corals (*Sarcophyton* spp., *Lobophyton* spp., *Sinularia* spp.)

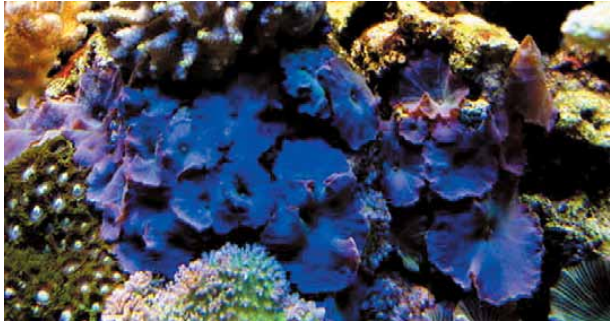

Mushroom anemones (here: *Discosoma* spp.)



Anemones (e.g. symbiotic anemones for clownfish)

Corals and other invertebrates



Colonial anemones (here: *Zoanthus* spp.)



with some experience, also stony corals (here: *Acropora Seriatopora* spp.)



Sea urchins (*Echinometra* spp.)



Brittle stars (*Ophiorachna* spp.)

Marine inhabitants that can be easily kept at the beginning

Suitable fish, shrimps and crayfish that can also be kept in an aquarium with invertebrates include:



Damselfish (*Chromis* spp.)



Dottybacks (*Pseudochromis fridmani*)



Gobies (*Cryptocentrus cinctus*)

Marine inhabitants that can be easily kept at the beginning



Cardinal fish (*Pterapogon* sp., *Sphaeramia*)



Clownfish (*Amphiprion* spp.)

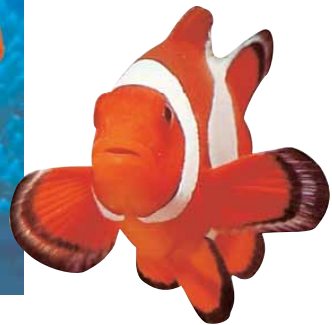

Wrasses (*Macropharyngodon* spp.)

Marine inhabitants that can be easily kept at the beginning

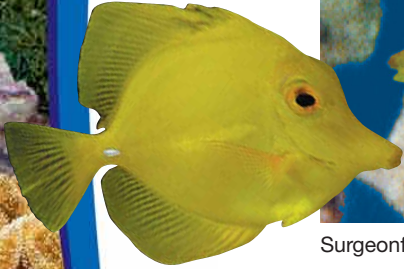

Surgeonfish/Tangs (*Zebrasoma* spp.)



Cleaner shrimps (*Lysmata* spp.)

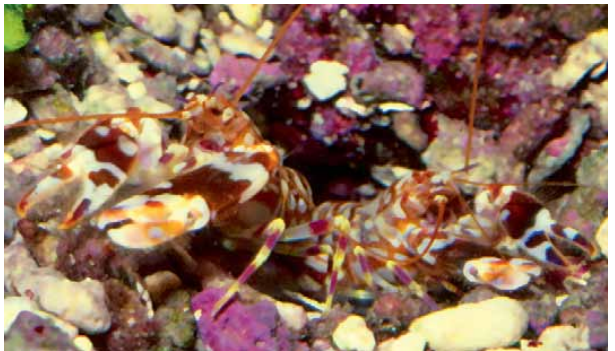

Pistol shrimps (*Alpheus* spp.)

2. Marine water biotope suggestions

sera gives you a couple of suggestions for marine biotope aquariums where everything is in balance. Along with the **sera** marin food and care products it is easy to successfully and easily maintain a marine aquarium even without aquarium experience.

The **sera** biotope aquariums match the ready-to-connect, completely equipped **sera marin Biotop Cube 130**. You can of course also set up other and larger aquariums with the **sera** marine biotope suggestions.

Some animals cannot be kept in aquariums, depending on their size, their nutritional habits and their other requirements. Also, you should not combine animals of different origins. This may lead to unnatural reactions and to stress among the species.

Stony corals are among the less suitable animals for compact size aquariums. They usually require strong and varying water currents as well as high intensity lighting. This is hardly possible in small aquariums. We recommend soft corals, which are easier to keep.

Of course you should not put large fish into a compact aquarium. Be sure to always ask your specialized retailer about the final size of a fish in question. Predatory fish are also not really an ideal choice, but rather friendly fish. From a design viewpoint, concentrating on one or two small species and setting up a part of a biotope looks best.



2.1 Biotope: Clownfish, anemone

Clownfish live together with different anemones in a symbiosis. The fish find shelter between the tentacles of the stinging anemone, they are immune against its venom. They also raise their offspring in the direct vicinity of the anemone. In return, the anemone profits from food not eaten by the fish and from their waste. Yellowtail damselfish, cleaner shrimps and sea urchins harmonize well with this main component.

Pile up large live rock chunks up to the half aquarium height in the back. Later on, you can plant bright green *Caulerpa* algae (1) on the uppermost rock chunks. The rapidly growing algae remove pollutants such as ammonium and nitrate from the water. The algae must be harvested regularly as to avoid it overgrowing other organisms in the aquarium. Please remove at least a third of the shoots each time.

Place flat live rock chunks, which are ideal for growing colonial anemones (2) and small soft corals (3) on them, in front of the large live rock chunks. Add one carpet anemone (4) in a central foreground position, surrounded by fine bright sand, as an eye-catcher.

Begin with adding the colonial anemones when you have added the live rock chunks. You should then add the carpet anemone in the foreground one or two weeks later. Please make sure the animal is not too large when choosing the anemone. We recommend only smaller animals with a diameter of max. 20 cm (8 in.). It is important that the anemone did not suffer from an injury during transport and that the oral disc of the animal is intact. The anemone requires an even, sandy place with a flat stone for settling in center position. It is also possible that the anemone attaches itself to the bottom glass pane of the aquarium. The clownfish (5) are added after the anemone has attached itself. Fish of the species *Amphiprion ocellaris* usually readily accept anemones of the genus *Stichodactylus* and retreat into the anemone.

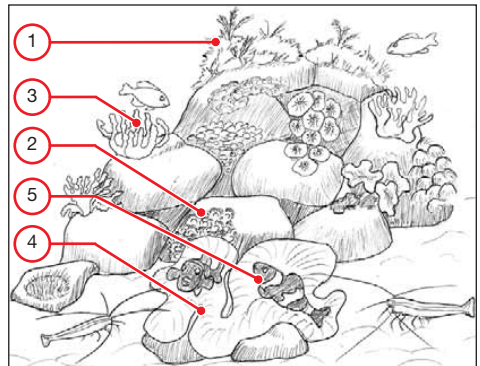

Recommended animals for the clownfish and anemone biotope

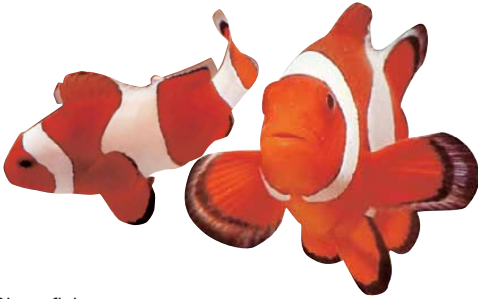

Clownfish
Amphiprion ocellaris
1 ♂, 1 ♀

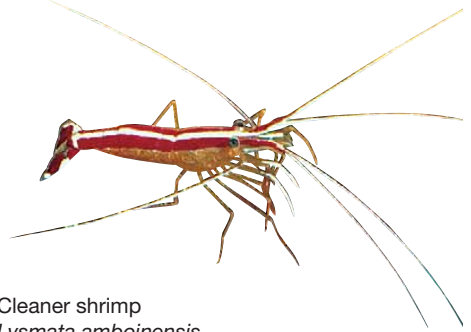

Cleaner shrimp
Lysmata amboinensis
2 specimens

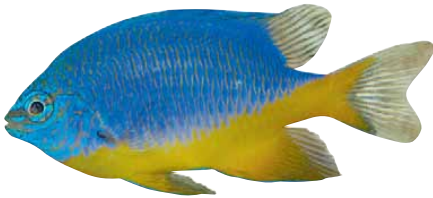

Yellowtail damselfish
Chrysiptera spp.
1 ♂, 1 ♀

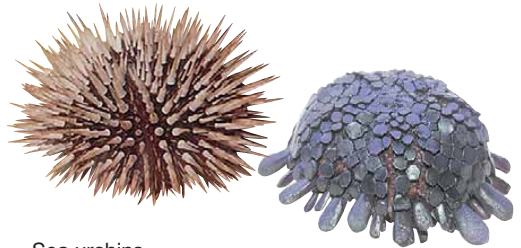

Sea urchins
Echinometra spp. or *Colobocentrotus* spp.
2 small specimens sized approx. 2 cm (0.8 in.)



Rhizome forming algae
Caulerpa spp.
A few scions



Carpet anemone
Stichodactylus spp.
In the foreground

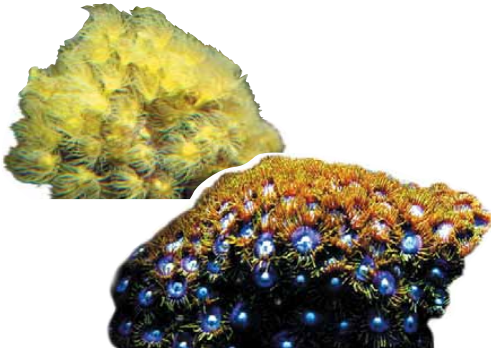

Colonial anemones
Zoanthus spp., *Protopalycha* spp.,
Parazoanthus spp.
 Several small colonies, each sized about 5 cm
 (2 in.), for settling the flat live rock chunks

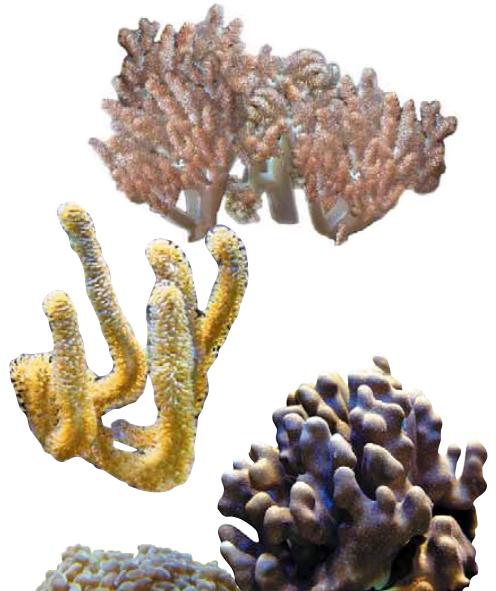

Heliopora spp.

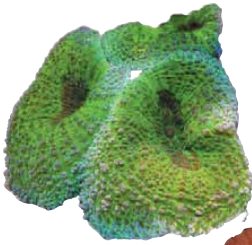

Euphyllia spp.



Mushroom anemones
Discosoma spp.
 Add 2 to 3 groups in different colors
 between the soft corals

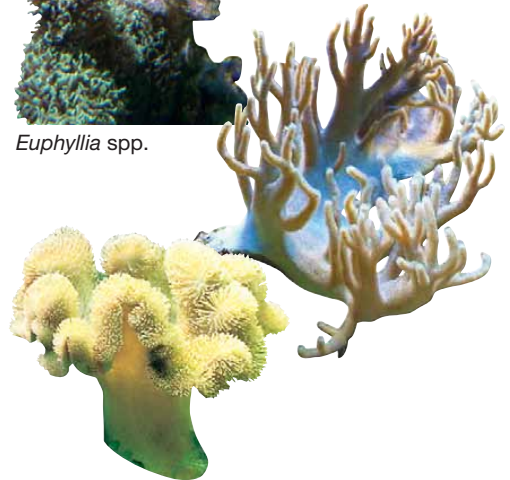

Soft corals, stony corals
Sinularia spp., *Sarcophyton* spp., *Lobophyton*
 spp., *Capnella* spp., *Xenia* spp.
 Place several small colonies, each sized about
 5 cm (2 in.), in front of the colonial anemones

Live rock
 10 to 14 large and 6 to 8 small chunks,
 about 15 kg (33 lb.) in total

2.2 Biotope: Reef pool

During low tide, many animals including brightly colored small fish and soft corals are isolated in reef pools, some of which are very small. This colorful living community consists of small fish (damselfish, gobies), shrimps, colonial anemones and soft corals.

First arrange the live rock setup as in the “clownfish, anemone” biotope, creating many small crevices and tiny caves. These will later on allow fixing sessile invertebrates and provide hideaways for small fish.

Start adding the corals. Soft corals (Kenya tree corals) (1), colonial anemones (2) and mushroom anemones (3) are placed in the crevices.

The added fish should be restricted to small species such as yellowtail damselfish (4) and gobies (5). Do not add more than 2 specimens of each species. If you have the possibility to distinguish the genders, always add a male and a female of one species. If there is no possibility to distinguish the genders, always select an adult and a small specimen of one species. The animals will then form a hierarchy without fighting.

2 cleaner shrimps (6) should also not be missing. As the species *Lysmata amboinensis* is hermaphroditic, they are always a pair.

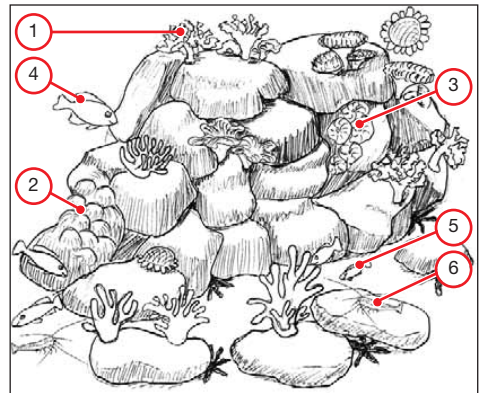

Recommended animals for the reef pool biotope

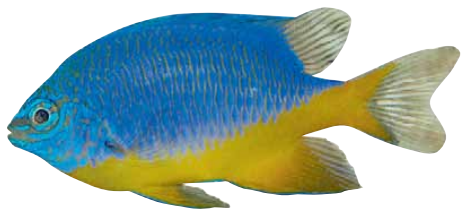

Yellowtail damselfish
Chrysiptera spp.
1 ♂, 1 ♀



Orchid dottedback
Pseudochromis fridmani
1 ♂, 1 ♀



Lemon goby
Gobiodon citrinus
1 ♂, 1 ♀

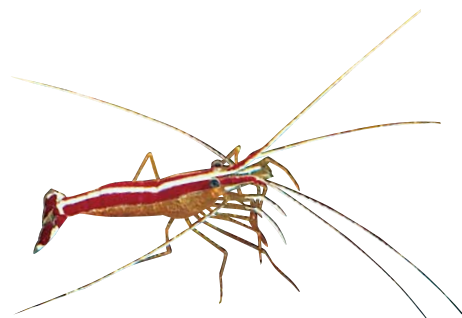

Cleaner shrimp
Lysmata amboinensis
2 specimens

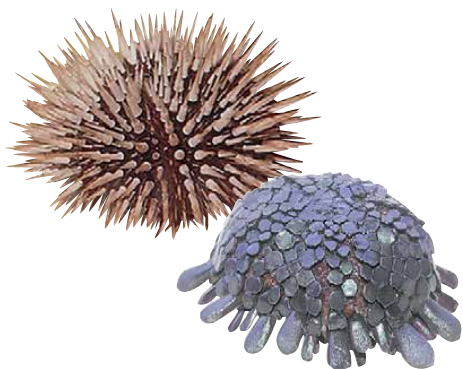

Sea urchins
Echinometra spp. or *Colobocentrotus* spp.
2 small specimens sized approx. 2 cm (0.8 in.)

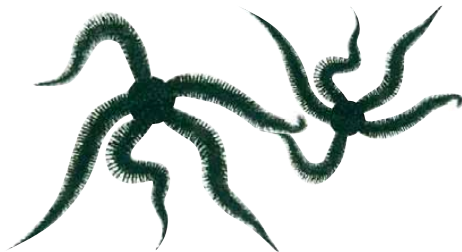

Small brittle stars
approx. 5 specimens

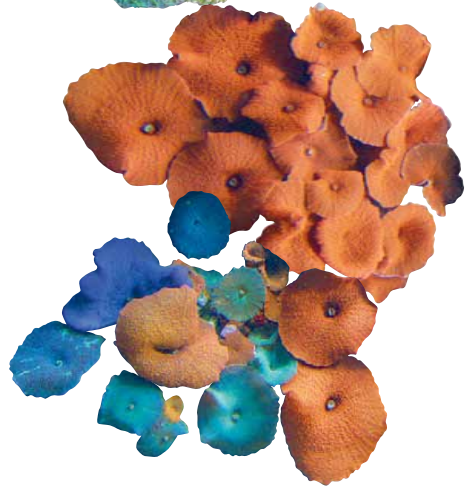
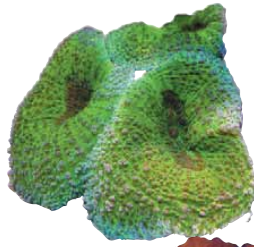

Mushroom anemones

Discosoma spp.

Add 2 to 3 groups in different colors
between the soft corals

Live rock

10 to 14 large and 6 to 8 small chunks,
about 15 kg (33 lb.) in total



Soft corals

Capnella spp., *Sinularia* spp., *Sarcophyton* spp.,
Xenia spp.

Several small colonies, each sized about 5 cm (2 in.)

2.3 Biotope: Gobies, pistol shrimps

Gobies like those of the genera *Cryptocentrus*, *Valencienna*, *Flabelligobius* or *Stonogobiops* permanently live together with pistol shrimps of the genus *Alpheus*. The shrimps have poor eyesight and build caves within the sediment that also serve as a living place for the fish. The fish even guard and supply the shrimps with food in return. These are very dynamic communities in which two completely different animals, fish and shrimp, have developed a way to communicate. This is an excellent example for co-evolution.

Set up the live rock chunks in a way that leaves a sandy area for the animals in the front part of the aquarium.

You will usually have only a few pistol shrimp (1) species to choose from: *Alpheus bellulus* and *A. randalli*. *Alpheus bellulus* is the much more active species that lives together with larger gobies (2) such as *Cryptocentrus cinctus*. Females have a much broader abdomen than males. Gobies of the genus *Stonogobiops* usually live together with the red and white *Alpheus randalli* shrimps.

A small live rock chunk placed in the center of the sandy area forms a first hideaway for the gobies and shrimps. Ideally, you can dig a little hole underneath the rock chunk with your finger. Add the animals one by one in a glass. Slowly turn the opening of the glass towards the bottom and place it upside down precisely in front of the rock chunk, where the hole is. The shrimp will immediately enter it and start digging. Proceed in the same way with the second shrimp. You can add the gobies to the shrimps about one hour later using the glass. By doing so, the gobies will find the shrimps much faster than if you just put them somewhere into the aquarium. The further setup can be done as soon as the center part of the symbiosis is established. Please read chapter 8 before adding the aquarium inhabitants. You can put the shrimps and gobies into the glass with a fish net and then proceed as described above.

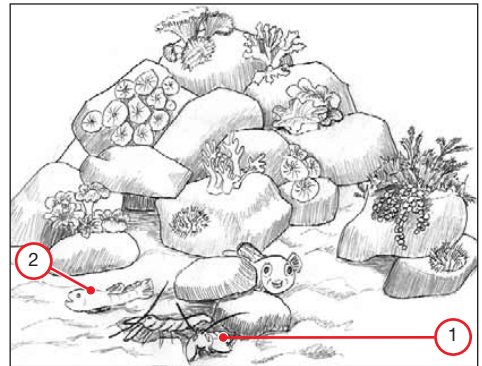

Recommended animals for the goby and pistol shrimp biotope



Gobies
Cryptocentrus cinctus or *Stonogobiops* spp.
1 ♂, 1 ♀



Pistol shrimp
Alpheus spp.
1 ♂, 1 ♀

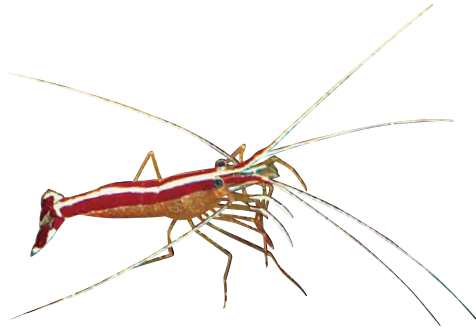

Cleaner shrimp
Lysmata amboinensis
2 specimens

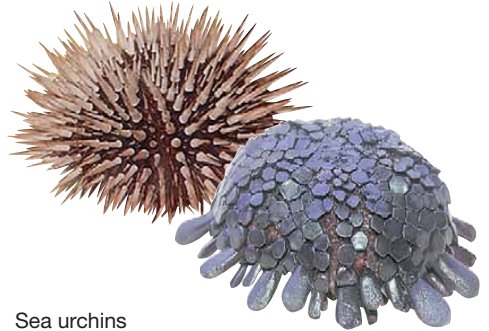

Sea urchins
Echinometra spp. or *Colobocentrotus* spp.
2 small specimens sized approx. 2 cm (0.8 in.)



Rhizome forming algae
Caulerpa spp.
A few scions

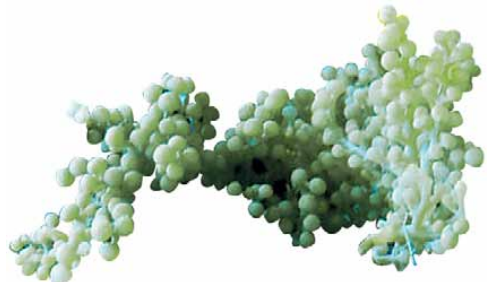

Rhizome forming algae
Caulerpa racemosa spp.
A few scions

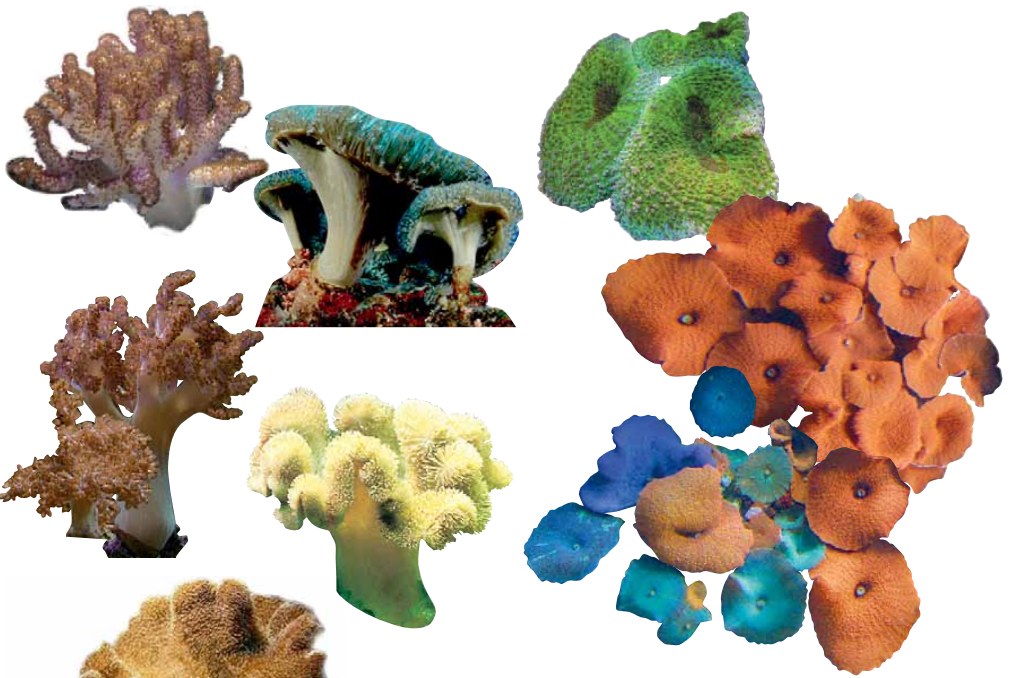

Mushroom anemones
Discosoma spp.
 Add 2 to 3 groups in different colors
 between the soft corals



Soft corals
Capnella spp., *Sinularia* spp., *Sarcophyton* spp.,
Lobophyton spp.
 Several small colonies, each sized about 5 cm (2 in.)

Live rock
 10 to 14 large and 6 to 8 small chunks,
 about 15 kg (33 lb.) in total

3. Technical equipment and filtration

3.1 Compact aquariums for an easy start into the marine world

With its complete plug-in equipment, the **sera marin Biotop Cube 130** is immediately ready for use and biologically active. It contains all technical equipment that you require.

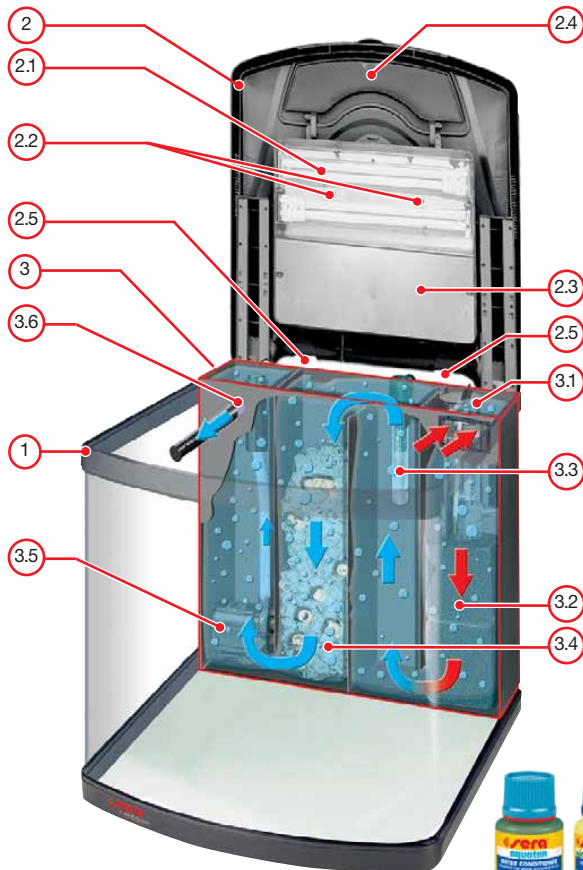

1 Aquarium with bow front

Polished glass
Volume approx. 130 liters
(34 US gal.)
Dimensions: W x H x D
51 x 66.5 x 57 cm
(20 x 26 x 22.5 in.)

2 Aquarium cover with

- 2.1 2 fluorescent tubes for aquariums T5 PL-24 W actinic blue light neutral daylight
- 2.2 2 LED lamps for moonlight simulation
- 2.3 2 fans for cooling electronic components
- 2.4 built-in food flap
- 2.5 openings for connecting a cooling system or accessories

3 4 chamber internal filter with sera marin Protein Skimmer PS 130

- 3.1 sera marin Protein Skimmer PS 130
- 3.2 2 filter sponges for mechanical filtration
- 3.3 sera heater 100 W
- 3.4 sera siporax 2,000 ml (580 g / 1.2 lb.) for biological filtration, with 540 m² (5,800 sq.ft.) filter surface

3.5 sera flow pump STP 1000

3.6 sera UV-C clarifier 5 W

100 ml (3.38 fl.oz.) **sera aquatan** water conditioner

100 ml (3.38 fl.oz.) **sera marin bio reefclear** biocultures for immediate biological pollutant breakdown

The **sera marin Biotop Cube 130** includes differently colored T5 PL lamps (2.1) that are optimal for a mixed stock of soft corals and fish.

The bioactive filter system immediately begins breaking down pollutants. This will save you a several week “activation phase”. Fish and other organisms can be added after a short time.

The **sera marin Biotop Cube 130** is completely equipped as a 130 liter (34 US gal.) marine aquarium, optionally with a matching cabinet.

The following advice is for setting up larger marine aquariums:

3.2 The optimal light

Fluorescent tubes, metal halide lamps (HQL) or their successors HCL or CDM, or a combination of both, are being used for lighting marine aquariums.

Water depth should not exceed 50 cm (20 in.) when using fluorescent tubes. Using the **sera Combi-Reflectors** increases light intensity by up to 100%.

In case you use light tubes, you should combine different light spectrums as to provide optimal light conditions. We recommend the **sera deep sea** as a foreground lamp. It provides actinic blue marine light and, with its specific light spectrum from 380 – 450 nm, ensures light conditions as in a tropic reef. Growth and coloration of invertebrates are strongly enhanced by the blue light spectrum. We recommend the **sera blue sky** for supplying the marine tank with tropical day-light.

The **sera** aquarium lamps are available as T8 and T5 tubes. The more intense T5 PL lamps are already included in the **sera marin Biotop Cube**.



3.3 The correct water temperature

Most aquarium fish are accustomed to water temperatures about 25°C (77°F). The aquarium water must therefore be heated accordingly. The aquarium heater must be attached in the aquarium in a way that the water always flows round it, in order to heat the water evenly. The required wattage is very easy to determine: Calculate approx. 1.5 Watts per liter (1 US quart) of water in rooms that are only slightly heated. If the aquarium is placed in a warm room, 1 Watt per liter (1 US quart) of water is sufficient. The heater may without hesitation be chosen in a stronger version; the power consumption for producing a certain amount of warmth is identical.

The stick-shaped **sera aquarium heaters** are entirely water-proof and marine water resistant. Temperature adjustment is particularly easy due to the adjustment wheel with temperature scale. **sera aquarium heaters** are available in many appropriately selected wattages from 25 Watts to 300 Watts and are fitted with a protective grid.



How to choose the right heater:

$\Delta T =$ 	aquarium size								
	liters	25	50	75	100	150	200	250	300
US gal.	6	13	20	26	40	53	66	80	
ΔT	5°C 9°F	25W	50W	50W	75W	100W	150W	200W	250W
	10°C 18°F	25W	50W	75W	100W	150W	200W	250W	300W
	15°C 27°F	75W	100W	150W	200W	300W	2 x 200W	2 x 250W	2 x 300W



Tip

A stronger heater has a higher power reserve, e.g., if the heating in your home should ever break down.



The correct **sera aquarium heater** for every aquarium size

3.4 Water purification

3.4.1 Removal of protein and other organic substances

The physical and chemical properties of marine water require additional filtration compared to freshwater. Protein dissolved in the water, e.g. from fish waste, is removed from the water by air being blown in. This task is fulfilled by the skimmer.

Skimmer tasks

A skimmer is the heart of marine aquarium filtration. It removes protein that is permanently released into the water by micro organisms, invertebrates and fish. The skimmer removes particles such as floating matter and aerates the aquarium. Protein not removed from the water will lead to an increasing amount of harmful substances such as ammonia, nitrite and nitrate (bacterial breakdown chain beginning with protein). Keeping marine organisms in closed systems would be considerably more difficult or, depending on the requirements of the species in question, even impossible.

Function principle

The dispergator pump of the **sera marin Protein Skimmer** draws in the water from the aquarium or from the filter chamber (1), mixes it with air drawn in by the resulting low pressure (3) inside the gyro case (2), where it is scattered into tiny air bubbles by the **sera** pinwheel. The fine air bubbles provide a large surface where the protein can settle.

This water/air mixture is pumped into the inner reaction chamber of the protein skimmer (4). The outlets directed sideways (5) make the mixture rotate, keeping the air bubbles floating for a longer time and therefore increasing the floatate yield. The protein attaches to the bubbles within this chamber. The bubbles accumulate at the water surface and form a solid foam while floating there. The narrowing standpipe of the foam cup directs this foam into the floatate cup where it is col-

lected (6). The purified water flows into the standpipe at the bottom end of the skimmer and back into the aquarium or filter tank through the outlet hose (7) connected to it.

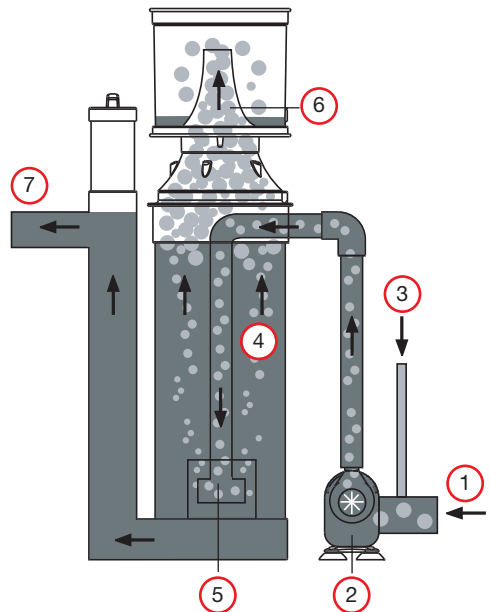

Skimmers reduce water pollution by proteins and other organic substances. They aerate the aquarium and provide it with oxygen. Skimmers need to be cleaned regularly, as to prevent skimmed waste matter from getting back into the aquarium.

sera marin Protein Skimmers are high performance, energy saving and flexibly usable dispergator skimmers. The **sera marin Protein Skimmer 400 HO** is suitable for aquariums up to 400 liter. It can be used as a hang-on version as well as a filter underneath the aquarium (sump). It is therefore optimally suitable for all aquarists that wish to switch over from freshwater aquariums to marine aquariums.

The **sera marin Protein Skimmer 600 S** is used in a filter underneath the aquarium (sump) for aquariums up to 600 liters.

The **sera marin Biotop Cube 130** includes the small but powerful **sera marin Protein Skimmer PS 130**.



sera marin Protein Skimmer 400 HO



sera marin Protein Skimmer 600 S

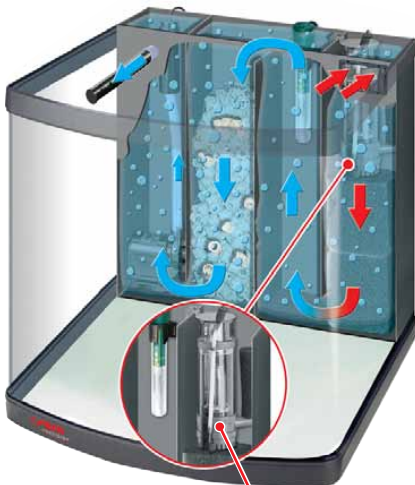

sera marin Protein Skimmer PS 130

3.4.2 Mechanical water purification

Large and solid dirt particles (such as uneaten food or algae particles) are collected in the mechanical filtration step as to prevent them from clogging biological filter media. In the **sera marin Biotop Cube 130**, filter sponges retain these coarse particles. This

considerably increases the biological efficacy of the filter.

These filter media must be washed out regularly as to avoid water pollution by waste products and ensure a high water flow rate.

3.4.3 Biological water purification

Useful bacteria clean the marine water by biological waste product breakdown. This includes non-skimmable substances such as ammonium, ammonia and nitrite. This purification process takes place in special filter media. Depending on the filter, there is a separate filter chamber as in case of the **sera marin Biotop Cube 130**.

Two components are crucial for the biological purification quality:

1. The filter medium
2. The purification bacteria

Filter media ensure optimal working conditions

The **sera siporax** filter medium has a unique surface structure. **sera siporax** provides ideal conditions for the different bacteria species in **sera marin bio reefclear**. The bacteria can optimally attach to the large, coarse surface. They are sufficiently supplied with oxygen and convert ammonium into nitrite in an aerobic process.

The extremely large amount of open-pored tunnel structures in **sera siporax** allows for ideal supply of anaerobic bacteria with nutrients and smallest amounts of fresh water. The bacteria are forced to break up nitrate as to get enough oxygen. This allows to also reduce nitrate continuously. Due to the large internal diameter of the tubes, the waste products are quickly transported away without continuously washing away the bacteria.



Important:

Filter media for bacterial settling should be tube shaped. This allows the water flowing off at the inside of the tubes. No clogging will occur, which would affect the filtration process.

The surface of one liter (one US quart) of **sera siporax** has almost as much biological breakdown power as 34 liters (9 US gal.) of ceramic filter material



You can check ammonium/ammonia, nitrite and nitrate with the **sera NH₄/NH₃-Test**, the **sera NO₂-Test** and the **sera NO₃-Test**, respectively.

Billions of purification bacteria in volcanic rock for permanent pollutant breakdown in aquariums

sera marin bio reefclear contains bacteria cultures in finely ground volcanic rock. Therefore, they already bring their settling space with them and can start water purification not only in the filter but also within the entire aquarium.

sera marin bio reefclear is simply poured onto **sera siporax** and directly into the aquarium. Brief mineral cloudiness will occur after addition to the aquarium water. It will vanish after some hours as the cleaning effect takes place. During this time, the volcanic rock binds floating matter that cause water cloudiness, and will leave the water as clear as never before. **sera marin bio reefclear** should be added regularly in weekly intervals as to achieve this positive effect permanently.



3.4.4 Pathogen reduction by UV clarification

The downstream UV-C device, such as the one in the **sera marin Biotop Cube 130**, ensures permanently healthy aquarium water.

- Pathogens in the water, that may adversely affect the animals, are reduced. In particular, the number of free swimming stages of white spot disease pathogens can be lowered with UV-C radiation. The pathogens become damaged, and rapid multiplication of these pathogens is prevented.
- All kinds of floating algae are reliably removed without using chemicals.

Aquarium inhabitants and filter organisms are not harmed by using UV-C water clarifiers. UV-C clarifiers should run 24 hours per day as to be effective. They will then maintain permanently biologically healthy water. The unit is switched off only when performing maintenance in the water.

The **sera UV-C System 5 W** for up to 500 liters (132 US gal.) of aquarium water is the ideal addition for filters without a built-in UV-C water clarifier. A powerful but at the same time very economical UV-C clarifier with multi-purpose connection for filters and pumps. The **sera UV-C System 5 W** can be used in combination with a flow pump such as the **sera P 1200**. The performance of the pump should be the volume of the aquarium per hour. The UV-C clarifier cannot be operated without a pump.



sera UV-C System 5 W
for adding to filters without UV

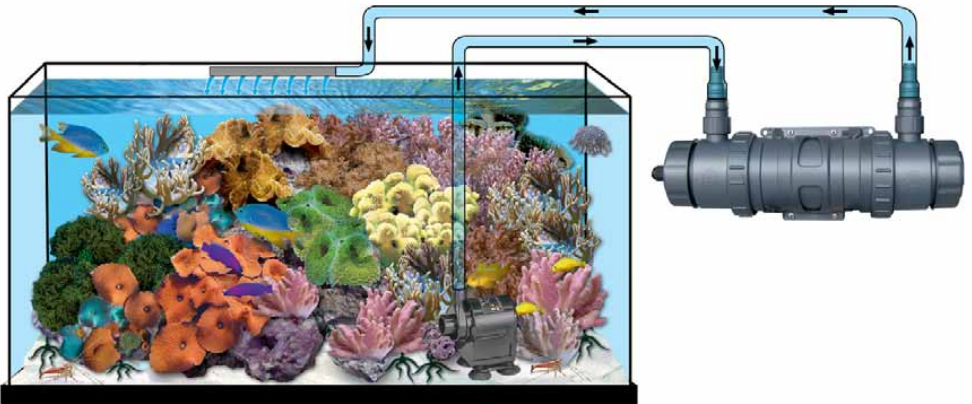

3.4.5 Special sera filter media

The standard equipment of the **sera** internal filters is entirely sufficient for permanently clean and crystal clear water. However, using additional filter media may become necessary due to external influences.

Further filter media can be used within the internal filter of the **sera marin Biotop Cube 130** without any problems. You can additionally simplify addition and removal with a **sera filter media bag**.

Removal of toxic substances

sera super carbon (filter carbon) is particularly pure and provides a large surface. It absorbs toxic substances from the aquarium within shortest time. Due to its very large surface, **sera super carbon** remains active for 6 weeks. Then its uptake capacity is spent, and the filter carbon must in any case be removed from the filter. Otherwise, substances already taken up can get back into the water again. **sera super carbon** does not affect the pH value and is free from phosphates and nitrates.

Removal of diatoms

Silicate supports the formation of diatoms in marine aquariums. In some areas, silicate is added to tap water by the water provider as to inhibit corrosion. By doing so, water providers protect the pipes, but indirectly harm every marine aquarium. **sera marin silicate clear** binds silicate permanently and, by doing so, withdraws the quickly growing diatoms their skeleton construction material.

The **sera SiO₃-Test** allows to easily monitor the levels in tap water or in the marine aquarium.





4. The correct location

When choosing the location, bear in mind that subsequently moving the aquarium is difficult. A decorated and filled 100 liter (26 US gal.) aquarium weighs up to 150 kg (331 lb. – without cabinet)! In older buildings we recommend that you gather information about the stability of the floor first. Take into account that the viewers' weight adds to the aquarium weight! A small aquarium can add to more than 300 kg (662 lb.) in a small area of floor space.

Quiet places in the room which are far from the window are best. Sunlight coming in through the window promotes algae growth. Furthermore, the fish start to swim in a slanting way as – frankly speaking – “up” to them is where the light comes from.

The aquarium optically stands out better in a dark corner of the room, and the fish are less frequently disturbed by persons rushing along, opening doors, etc.

The rack

In case you do not want to place the aquarium on a cabinet, you will need a suitable rack. It must be stable and stand exactly horizontally. A spirit level is very helpful.

The **sera marin Biotop Cube 130** is equipped with a glued-on safety frame. Place the aquarium with its frame directly onto the cabinet. Do not use any additional mats.

Aquariums without a safety frame require a safety pad and heat insulation below the aquarium as to avoid tension caused cracks. The **sera thermo-safe** safety pad reduces the danger of breaking glass caused by e.g., single sand grains or tension caused cracks caused by torsion of the wooden cabinet.



5. Sea salt: The basis for life in a marine aquarium

Using natural marine water is not possible and also not advisable. Marine water for aquariums is prepared with synthetic sea salt, as marine water inhabitants require stable conditions without much variation.

sera marin basic salt is very homogenous. It dissolves to crystal clear marine water quickly and without residues. The pH value precisely and reliably stays within the correct range due to the natural buffer system in the sea salt. **sera marin basic salt** provides natural pH and KH values, and it is free from nitrates, silicates and phosphates. Marine water conditioned with **sera marin basic salt** has biologically correct calcium and magnesium levels.

sera marin reef salt has the same properties as **sera marin basic salt**. Furthermore it is a sea salt similar to nature and provides high-

est quality for splendid reefs. The separate components are blended in a way that ensures there are no pollutants included. It is always possible to obtain reproducible results. Even very sensitive organisms do not react stressed after water changes. The requirements of even most fastidious invertebrates are fulfilled, and deficiencies are efficiently prevented.



5.1 How to condition tap water

Tap water contains a large number of additives and natural substances that make the water suitable for human consumption but may harm the inhabitants of a marine aquarium.

A reverse osmosis (R/O) or ion exchange system is by all means recommended in areas with tap water rich in nitrates or phosphates. This water purification will remove about 95% of all dissolved pollutants from the water.

You should condition the water with **sera aquatan** as to protect the aquarium inhabitants and bind present heavy metals and chloramines. These harmful substances can be present even in water conditioned with reverse osmosis (R/O) and harm the animals.

sera aquatan with the **Bio Protect Formula** provides many advantages for the marine water inhabitants:

- immediate removal of aggressive chlorine
- immediate binding of heavy metals
- splendid colors and vitality
- mucous membrane and gill protection by skin protecting colloids
- less stress and nerve system support due to vitamin B



Fish and invertebrates feel visibly better in healthy water, and aquarium maintenance causes less efforts.

5.2 How to prepare marine water

It is best to prepare the marine water in a suitable and sufficiently large container, e.g. a rain barrel made of plastic (as it is corrosion proof). Follow the instructions for the sea salt you use.

The nitrate level should be below 10 mg/l (ppm), phosphate and silicate should not be detectable. Check the water with the **sera phosphate-Test**, the **sera silicate-Test** and the **sera nitrate-Test** for being sure. You can also ask your local water provider for the measured values or look them up on the internet.

The salt is now by and by added to the water while stirring, until you achieve a salinity of approx. 35 per mille (i.e. 35 grams per liter of water). This corresponds to a density of

1.023 g/cm³ at approx. 25°C (77°F). Depending on the setup, you will require about 130 – 150 liters (34 – 40 US gal.) of marine water for a 130 liter (34 US gal.) aquarium. You will need about 5 kg (1.1 lb.) of sea salt.

The marine water should be agitated by a pump in the container and aerated for about 24 hours. The water will then appear perfectly clear.



5.3 How to measure salinity

The **sera marin hydrometer** is put into the aquarium or a bigger glass filled with the water which should be tested, in a manner that it can float freely. The hydrometer will be immersed the deeper, the less salt there is in the water. It will display the density of the water on the integrated scale. The density should be 1.022 – 1.024 g/cm³ at approx. 26°C (79°F) in aquariums with invertebrates.

If necessary, add more salt or dilute with conditioned water. However, the marine water is not put into the aquarium yet.

Density at	Salinity 33 ‰	Salinity 34.5 ‰	Salinity 36 ‰
16°C	1.025 g/cm ³	1.026 g/cm ³	1.0265 g/cm ³
20°C	1.0235 g/cm ³	1.025 g/cm ³	1.0255 g/cm ³
25°C	1.022 g/cm ³	1.023 g/cm ³	1.024 g/cm ³
28°C	1.0215 g/cm ³	1.0225 g/cm ³	1.023 g/cm ³
30°C	1.020 g/cm ³	1.0215 g/cm ³	1.0225 g/cm ³



6. Setup

6.1 Bottom gravel

Coarse coral sand is excellently suitable for the marine water aquarium. It is decorative and contributes to pH value stabilization due to its lime contents.

However, some fish species (e.g. gobies) by all means require a zone with sandy bottom material into which they can retreat during the night. A separate zone with fine coral sand must be arranged at the bottom for these animals.

The remaining bottom area is covered with an approx. 3 cm (1.2 in.) thick layer of coarse coral sand. It is advisable to separate the different kinds of bottom material from each other with stones as to prevent them mixing up. Coral sand of different grain sizes is available from your local specialized retailer.

Another important bottom ground task is to provide additional settling space for the bacteria that require oxygen (aerobic) in the upper zones and for the bacteria living without oxygen (anaerobic) in the lower zones. These purification bacteria in **sera marin bio reefclear** break down pollutants as in the filter.



The dry coral sand must first be washed thoroughly. Put it into a clean bucket in portions, and pour about 4 – 5 liters (1 – 1.3 US gal.) of warm tap water on top of it. Stir the sand with thorough, circulating hand movements, then pour away the water along with the pollution. Repeat this procedure until the sand appears clean. Now fill the sand into the still empty aquarium.



6.2 Live rock

You now require the live rock chunks, which can easily be transported and stored moist for a couple of hours. However, the longer the rock chunks are exposed to air, the more attached biomass may die.

When purchasing them, see that the rock chunks have good and diverse growth on them, and that they have different shapes. The more diverse the growth attached to the rock chunks and the shorter they were stored at the retailer's, the more different animal species are attached to them. You will find these animals in your aquarium later on. By no means ever wash live rock with freshwater.

The rock chunks should be piled up in a way that small caves are formed, into which the animals can retreat later on. Also, such an open setup allows for good and hardly inhibited water agitation. Take your time when building the setup. The rocks should not cast shadows on the ones underneath them, as a



shadowy place is not suitable for positioning animals that require light. The construction must be firm and must not totter, because rocks falling down might damage the bottom or side panes of the aquarium or injure aquarium inhabitants. Allow for crevices between the rock chunks that serve for fixing sessile invertebrates.



Examples of overgrown live rock with additionally added invertebrates in larger marine aquariums

7. Filling in marine water

In aquariums with internal filters pour **sera marin bio reefclear** over the **sera siporax** in the biofilter chamber before filling the aquarium with marine water. In case of external filters, pour **sera marin bio reefclear** over **sera siporax** before the filter is filled with water (please also see page 26). The purification bacteria will then settle immediately on and in the porous filter material. They can optimally multiply there and quickly start their purification work. This considerably shortens the biological activation phase of the aquarium.

The aquarium is filled to the upper edge with the matured marine water. It is best to allow the water to flow into the aquarium over a plate. Otherwise, all the bottom gravel will be stirred up. You can store possibly remaining water in the plastic barrel under aeration and use it for the first water change.



7.1 Starting filtration and technical equipment

Switch on the filter equipment after you have filled the aquarium. Switch on the units in the following order: submersible pump, UV clarifier, skimmer and heater [set the temperature to 26°C (79°F)]. You can now watch how the

water flows back to the spray bar attached to the outlet and circulates. Air from the outside is blended with water drawn inside the skimmer. From now on, the water is constantly purified.

7.2 Topping up water

As in every other aquarium, water will evaporate. Depending on the situation, top up evaporated water every 2 – 3 days: Use tap water conditioned with **sera aquatan** to do so, as the salt dissolved in the marine water does not evaporate. The salinity would slowly rise if you would not top up water, which is

tolerated by the animals only to a certain extent. There will be no harm as long as the salinity is between 34 and 36 per mille. However, the more constant you keep the salinity at 35 per mille, the better for your animals.

8. Watch your aquarium come to life

Many small animals and almost certainly some beautiful algae species have entered your aquarium with the live rock chunks. They will become visible soon. However, it is possible that some of the animals growing on the rocks (e.g. sponges) do not survive.

If an invertebrate obviously does not survive, remove it as to prevent too strong water pollution. You must in any case add bacteria cultures from **sera marin bio reefclear** that break down pollutants.



8.1 The first days – “The activation phase”

Switch on the light for 8 – 10 hours per day. If you wish to automatize the light switching you should get a timer that you can program accordingly.

You can feed the small organisms with a small amount of **sera marin coraliquid** for the first time after about 2 weeks. In this activation phase no other animals should be added during the first 2 weeks.

You should replace approx. a third of the water each week during the first 3 months with matured marine water (always ensure correct salinity!). Enhanced algae growth taking place during the first few weeks is perfectly normal. Usually, a slight cover of red algae appearing brown and slimy comes first, which is replaced by green algae after a few weeks. The green algae indicate that you can now add the first organisms. You can care-



fully remove algae mechanically with a small brush (e.g. clean toothbrush). It makes sense to carry out a partial water change afterwards, using a hose or the **sera gravel washer** to remove the water from the aquarium along with the algae.

When using a magnifier you will be able to discover small crustaceans such as isopods or copepods on the aquarium glass. These are important for every aquarium and its manifold life forms. They have entered the aquarium with the live rock chunks. By and by, further life forms brought in with the live rock will establish. These small organisms make the activation phase, but also the con-

tinuing operation of the aquarium an exciting expedition into the world of small creatures.

You can then introduce the animals after 2 weeks.



8.2 How to introduce and acclimatize the animals

Some marine animals must not leave the water while transferring them to another location. Even a few seconds of being exposed to air may harm them. Sea urchins, starfish and pufferfish are among these air sensitive animals. Do not add all invertebrates and fish at once. Start with the invertebrates and add the fish afterwards.

Make sure these animals are placed in the transport bag **under water** when purchasing them.

Please ask your retailer how the purchased animals must be introduced into the aquarium. Transfer into another aquarium causes a climate change for the fish and invertebrates. It is usually advisable to proceed as follows: At home, transport bags with the newly purchased fish and invertebrates are opened and placed side by side in a bucket. Aquarium water is **dripped** into the transport bags during the next half hour. An air hose fitted with a clamp are suitable for this purpose.

By doing so, the animals not only adapt to the “new” water temperature but also to the other water parameters (salt content, pH value, etc.).



sera aquatan accelerates the healing process of the mucous membrane if it has been damaged during transport.



9. Regular maintenance

9.1 Feeding

Staple diet

Marine fish require much more iodine and other minerals than freshwater fish. More than 50 ingredients in **sera** fish food ensure feeding the aquarium inhabitants a balanced diet according to nature. This supports disease resistance and prevents deficiencies.

All **sera** foods are very low in phosphates and very easy to digest, thus preventing water pollution by undigested breakdown products.



sera marin coraliquid, a plankton based liquid food rich in energy, was specially developed for filtering invertebrates.



sera marin GVG-mix is a flake food with added treats for marine fish. This versatile basic food contains iodine and other minerals from marine algae, krill, plankton and other valuable ingredients such as bloodworms, daphnia and Artemia shrimps.



sera marin granules is an ideal food for fish that search for their food between coral branches, in the middle water layers or near to the bottom. It sinks slowly, softens quickly but keeps its solid consistence. Therefore it prevents water pollution.



sera has developed the innovative crustacean foods **sera crabs natural** and **sera shrimps natural** for the various requirements of the crustaceans. The valuable ingredients and the careful processing make these foods an ideal staple diet for crustaceans. The unique nutrient composition results from the sole use of aquatic organisms such as marine fish, gammarus, spirulina and marine algae as protein and fat suppliers. The proteins they contain are therefore characterized by an amino acid composition that can ideally be utilized by the crustaceans.



Healthy treats



sera Spirulina Tabs can be attached to the glass inside the aquarium. This completely vegetable tablet in premium quality contains more than 20% of Spirulina algae. **sera Spirulina Tabs** are indispensable for algae-eating animals such as surgeonfishes or blennies.



sera FD Krill is a food of carotene rich small crustaceans that live in the ocean and feeds on plankton. **sera FD Krill** is very rich in protein. It is ideally suited for strengthening fish and increasing the readiness to spawn.



sera FD Artemia Shrimps consist of tender brine shrimps. They are a healthy treat for all marine fish.



9.2 Water changes

Regular water changes of 10% per week, beginning after the first three month activation phase, are an important contribution to successful care. It is advisable to clean the bottom gravel along with the water change. This is easy to do with the **sera gravel washer**.

You can avoid salinity variations with a marking on the outside of the aquarium. Always top up the aquarium with water up to the marking as to replenish the evaporated water. The water is always conditioned with **sera aquatan** for pollutant removal.

You will need:

- A watering can and two clean buckets reserved only for the aquarium. They must never have been in contact with cleaning agents
- Two meters of aquarium hose or, even better, a **sera gravel washer**
- A towel or a shallow bowl in case of spilling water
- By all means pull the mains plugs, e.g. those of the heater, the filter, and the lighting

First place the two buckets on the towel or in the bowl. Then let the water flow from the aquarium into the buckets. There are different ways to do so:

Many aquarists hold the hose end into the aquarium and then briefly suck the water from the other end with their mouth. However, this method requires some practice. Sometimes, the water either will not flow, or you may accidentally swallow a big gulp of aquarium water.

You can siphon the water off more elegantly with the **sera gravel washer**. By doing so, you will serve two purposes at once. You will easily and thoroughly remove sludge from the aquarium gravel with the **sera gravel washer**, and you will change a part of the water at the same time.

After you removed the aquarium water as far as necessary, you can now also perform smaller cleaning activities.



An important tip

Mark the outside of the aquarium glass with adhesive tape or the like up to where you wish to empty the tank.





9.3 Supplying trace elements, calcium and macro elements

These substances must be replenished regularly for maintaining natural conditions in a marine aquarium, especially after a water change. This is the only way to ensure optimal, healthy growth of the animals. In particular corals, but also snails and clams withdraw calcium and trace elements from the water. Also, bacteria in the sediment can reduce these elements by precipitation.

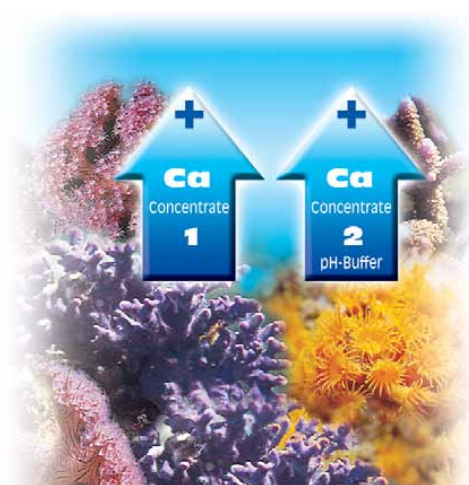
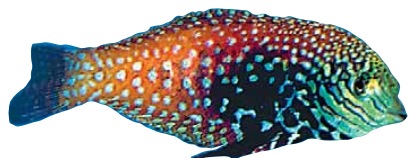



1+2 Calcium hydrogen carbonate

Acidic or alkaline influences may strongly alter the pH value of the aquarium water if the calcium hydrogen carbonate concentration becomes too low. Because of the sensitivity of the marine water inhabitants you must by all means avoid this.

Regular addition of **sera marin COMPONENT 1 Calcium** and **sera marin COMPONENT 2 Calcium pH-Buffer** allows maintaining an even concentration in an uncomplicated way. The two component buffer system requires two bottles. Both components are present in high concentrations, which would not last when combined. The calcium level in nature is approx. 450 mg/l (ppm), the carbonate hardness is approx. 9°dKH. It is advisable to raise the carbonate hardness to 10°dKH in an aquarium. You can reliably monitor the calcium level and the carbonate hardness with the **sera Ca-Test** and the **sera kH-Test**, respectively.

Why do these levels sink? Corals and mollusks, in particular, precipitate calcium hydrogen carbonate as calcium carbonate by means of their endosymbiotic algae, using it as construction material of coral skeletons and mollusk shells! A growing coral thus withdraws a part of the buffer system from the water. Some mollusks are also able to do so. For example, giant clam species (Tridacnidae), which become more and more popular, withdraw calcium hydrogen carbonate from the water for their shell growth! Bacteria living in the bottom gravel can also cause local precipitations due to their metabolic products.

3+4 Trace elements

Many metabolic processes in animals and plants require catalysts. They activate reactions of single components and lead to the formation of certain substances required within the organism. These biological catalysts are called enzymes. Rare metal ions play a key role in some of these enzymes. They originate from the marine water and are taken up by the animals either from the water or with the food.

The trace elements are present in the **sera marin COMPONENT 3 trace elements Anionics** and **sera marin COMPONENT 4 trace elements Kationics** solutions. Regular addition is by all means necessary as these trace elements are consumed by animals and plants.

Trace elements are not only important in enzymes, but they are also present in certain color pigments. They can be found in the coral tissues of stony corals, especially in parts of the colony that are exposed to direct sunlight. It is likely that they reduce the influence of aggressive sunlight. Keepers of stony corals wish to achieve the same color intensity of the animals kept in the aquarium as in nature or even enhance it. This is possible, even under aquarium light, which is weak compared to natural sunlight (approx. 5,000 Watt/m²). An elevated level was found to lead to enhanced color intensity of stony corals under aquarium conditions. Accordingly, some brown *Acropora* corals turn into violet ones within only a few weeks!



5+6 Strontium and magnesium

Regarding their natural concentrations, the so-called macro elements are situated between the common and the trace ions. Strontium and magnesium are among them. It is known that available strontium ions are utilized in the skeleton of stony corals and therefore must be replenished. Magnesium is mainly taken up by coralline algae. These settle on live rock as a violet cover. However, there are also many species whose shape resemble small trees. Natural magnesium levels of 1,250 – 1,300 mg/l (ppm) provide good conditions for the growth of these algae. Both metal ions are present in high levels in **sera marin COMPONENT 5 strontium** and **sera marin COMPONENT 6 magnesium**, respectively. Be sure to avoid overdosing, as this would reduce the calcium level. Many marine aquarists are not aware of this, and they reduce the amount of available calcium by too high additions, especially of magne-

sium. Calcium, strontium and magnesium are among the alkaline earth metals. This group features similarities in its physical characteristics, leading to similar chemical and physical properties. It is therefore by all means necessary to get an overview on the current values by means of water test kits, and to monitor the increased concentration after adding the water conditioners. You can reliably monitor the magnesium level with the **sera Mg-Test**.

7 Iodine

Iodine does not remain active in the water very long. Iodine is precipitated by high concentrations of other ions. It is thus removed from the water and becomes unavailable for

the aquarium inhabitants. A constant iodine level is achieved by daily addition of **sera marin COMPONENT 7 iodine**.



9.4 Monitoring and adjusting pH value, carbonate hardness and carbon dioxide

The oceans represent the most stable ecological system on earth. The ocean inhabitants have adapted to the constant physical and chemical parameters over millions of years. As these parameters vary only slightly in nature, most of the ocean inhabitants are much less adaptable than freshwater inhabitants. Because of this, the aquarium water must provide stable conditions without drastic fluctuations.



pH pH value

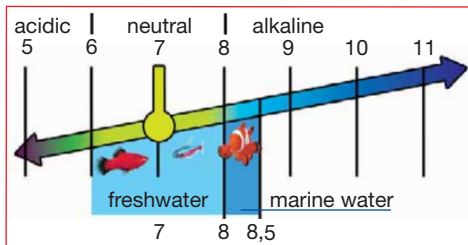

The pH value describes whether the water reacts acidic (pH below 7), neutral (pH = 7) or alkaline (pH above 7). The pH value in natural marine water is slightly alkaline (pH 8 to 8.5).

The pH in an aquarium is lower in the morning than in the evening. This is due to the fact that during the day carbon dioxide (CO₂) is consumed by the algae. As a result of the consumption of carbonic acid, the pH value will rise during the day.



Caulerpa

The pH value of the aquarium water should be checked regularly. The **sera pH-Test** allows easy monitoring of the pH value. Use **sera KH/pH-plus** for increasing the pH value.

Due to their high CO₂ requirements, the pH value may rise over 8.5 if you keep plenty of macro algae (*Caulerpa*, *Halimeda* etc.).





kH Carbonate hardness (KH)

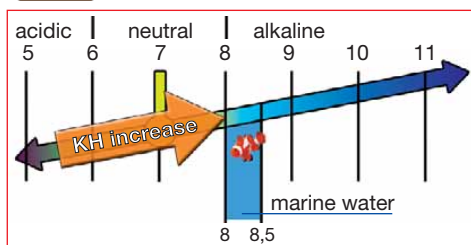

The carbonate hardness (KH) in the water serves as a buffer. It is able to neutralize acids and therefore absorbs small fluctuations of the pH value. In order to provide a buffering effect that is strong enough for a marine aquarium, the carbonate hardness must not fall below 8°dKH.

You can quickly and precisely check the carbonate hardness with the **sera kH-Test**. Increasing the KH level is easy and safe with **sera KH/pH-plus**.



CO₂ is only used in calcium reactors in marine aquariums. This device is usually placed in the sump and provides the aquarium with calcium hydrogen carbonate. The water inside the calcium reactor is acidified by the introduced CO₂ and dissolves the calcium carbonate inside the device. Soluble calcium hydrogen carbonate gets released as a reaction product. The amount of water taken up by the calcium reactor in the filter underneath the aquarium (sump) is the same as the released amount.

The CO₂ supply for the calcium reactor is best controlled by a pH controller such as the **seramic pH Controller**. The device interrupts the CO₂ supply as soon as the adjusted pH value is reached. A pH value lowered to at least 6.5 by CO₂ is required for converting calcium carbonate into calcium hydrogen carbonate, for higher performance possibly a pH value lower than 6.0. This pH value can be automatically maintained by the **seramic pH Controller**, provided the pH measuring probe is located inside the calcium reactor.

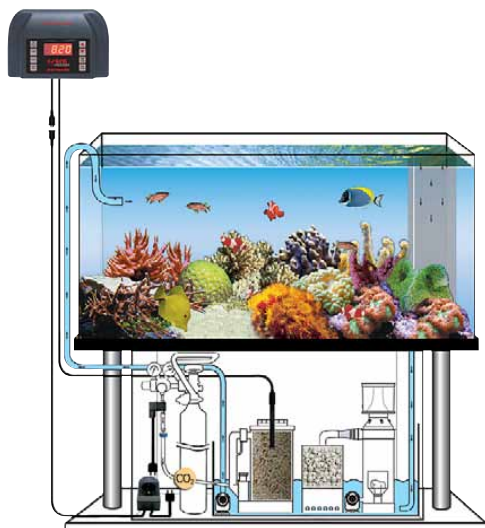

9.5 Monitoring ammonium, nitrite and nitrate

Organic waste products in the aquarium result in a nitrogen pollution of the water. Those waste products include fish waste, uneaten food and dead algae as well as dead animals.

Nitrogen occurs in the aquarium in different forms. Excess protein, ammonium resp. ammonia, nitrite and nitrate are nitrogen containing waste products in the aquarium.

The useful bacteria in **sera marin bio reefclear** convert dead plant parts, uneaten food and fish waste from ammonium via nitrite into harmless nitrate. Macro algae such as *Caulerpa* then considerably lower the nitrate level.

Organic waste products contain proteins, from which ammonium or ammonia is formed by biological decomposition. The ratio between relatively harmless ammonium and toxic ammonia is determined by the pH value. The higher the pH value, the more ammonia is formed. Since the pH value in marine water is always above 7, the ammonium level must be monitored very carefully.

The total concentration of ammonium and ammonia is checked with the **sera ammonium/ammonia-Test**. In case the measured level is above 0.2 mg/l (ppm), you must carry out a partial water change and add **sera marin bio reefclear** immediately.

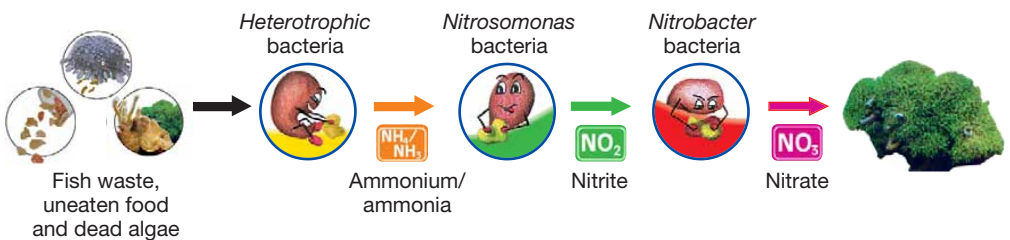
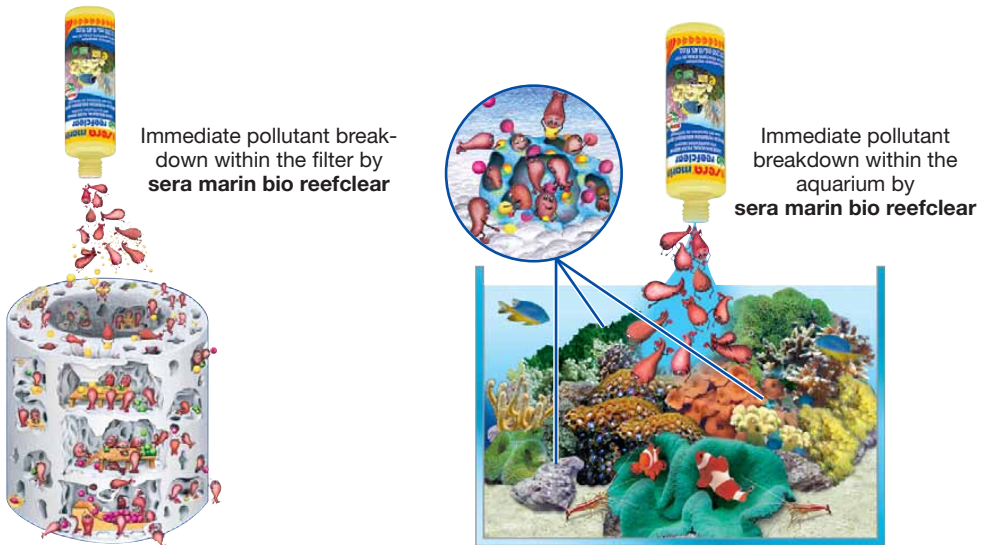

Biological breakdown of ammonium/ammonia to nitrite



The next step in the nitrogen cycle is the biological conversion of ammonium or ammonia to nitrite by *Nitrosomonas* bacteria. The bacteria need oxygen to do so. This process is called **aerobic** (with oxygen). Nitrite is highly toxic to fish and invertebrates.

Elevated ammonium, nitrite or nitrate levels are either due to mistakes or insufficient aquarium maintenance or to insufficient settling space for useful bacteria. The nitrite level of the aquarium water is checked with the **sera nitrite-Test**. A partial water change is necessary if the value exceeds 0.3 mg/l (ppm).

The ammonium and nitrite levels can be lowered with **sera marin bio reefclear**. **sera marin bio reefclear** contains bacteria that break down ammonium and nitrite and is therefore effective merely biologically. The liquid product is simply added to the aquarium water and to the filter medium (please see page 26).

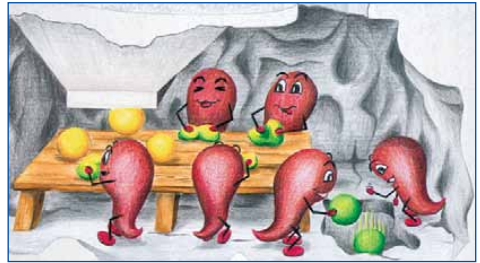

Biological conversion of nitrite to nitrate



The biological decomposition of nitrite by *Nitrobacter* bacteria leads to nitrate. The bacteria need oxygen also for this step. *Nitrosomonas* and *Nitrobacter* bacteria live in all zones of the aquarium rich in oxygen. This includes the upper gravel layers, the filter and the outside of the live rock. Water rich in oxygen is therefore important not only for fish and invertebrates.

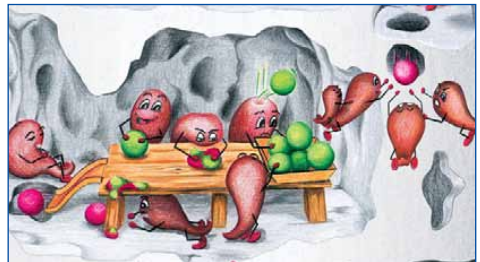

Nitrate uptake by macro algae



Nitrate is considerably less toxic than ammonia and nitrite. Nevertheless, concentrations above 20 mg/l (ppm) harm sensitive corals. It also supports the growth of unwanted thread and slime algae. Macro algae such as *Caulerpa* withdraw nitrate from the water and considerably reduce pollution. You can check the nitrate level with the **sera nitrate-Test**.

Bacterial nitrate breakdown can only take place in zones low in oxygen, where the bacteria take oxygen from nitrate. This process is called **anaerobic** (without air) or **anoxic** (without oxygen). Harmless nitrogen gas escapes into the atmosphere as the final product. The biological breakdown of nitrate takes place in the bottom ground, but mainly in filter media such as **sera siporax**.

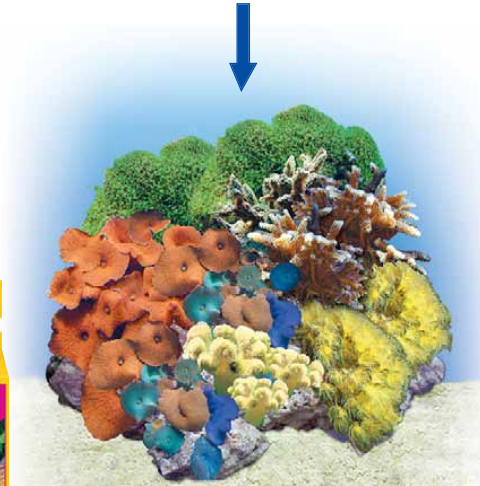
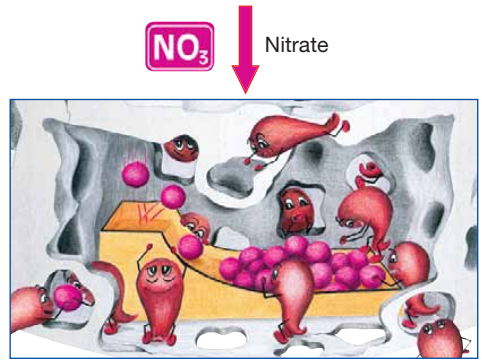

Crystal clear, biologically healthy aquarium water



9.6 Checking the water

Parameter When to check?	Ideal parameter	Value too high – lower Value too low – raise	↓ ↑
pH weekly	8.0 – 8.5	<ul style="list-style-type: none"> ↓ • Partial water change with more acidic water • Add CO₂ 	↑
KH Carbonate hardness weekly	8 – 12 °dKH	<ul style="list-style-type: none"> ↓ • Partial water change 	↑
Ca Calcium weekly	400 – 450 mg/l (ppm)	<ul style="list-style-type: none"> ↓ • Partial water change 	↑
Conductivity weekly	50 – 54 mS/cm	<ul style="list-style-type: none"> ↓ • Partial water change with water of little less conductivity 	↑
Density weekly	1.022 – 1.024 g/cm ³ at 25°C (77°F)	<ul style="list-style-type: none"> ↓ • Partial water change 	↑
NH ₄ /NH ₃ Ammonium/ Ammonia weekly	ideal: 0.0 mg/l (ppm) dangerous from 0.02 mg/l (ppm) depending on the pH value	<ul style="list-style-type: none"> ↓ • Partial water change (check pH value) • Avoid still water zones by providing water currents (use a powerhead) • Add sera marin bio reefclear • Check/clean the filter • Reduce number of fish • Feed sparingly 	
NO ₂ Nitrite weekly	ideal: 0.0 mg/l 0.3 – 0.9 mg/l (ppm) NO ₂ [equals 0.1 – 0.3 mg/l (ppm) NO ₂ -N]: water pollution from 0.9 mg/l (ppm) NO ₂ [equals 0.3 mg/l (ppm) NO ₂ -N]: danger for fish 3.3 mg/l (ppm) NO ₂ [equals 1.0 mg/l (ppm) NO ₂ -N]: acute danger to fish life	<ul style="list-style-type: none"> ↓ • Add sera marin bio reefclear • Check the filter • Feed sparingly • Check whether a fish or another animal is missing • Partial water change • Remove cause 	↑



Parameter When to check?	Ideal parameter	Value too high – lower Value too low – raise
NO ₃ Nitrate weekly	ideal: maximum 20 mg/l (ppm) from 20 mg/l (ppm) above 100 mg/l (ppm)	<ul style="list-style-type: none"> Use 1 liter (1 US quart) sera siporax per each 100 liters (26 US gal.) of water in the biofilter. To do so, activate the filter with sera marin bio reefclear Carry out frequent partial water changes with water that is low in nitrate Reduce fish stock if applicable Feed sparingly Use a protein skimmer Partial water change
Mg Magnesium weekly	about 1300 mg/l	<ul style="list-style-type: none"> Partial water change Add sera marin COMPONENT 6 magnesium
PO ₄ Phosphate weekly	max. 0.1 mg/l (ppm) ideal: below 0.05 mg/l (ppm)	<ul style="list-style-type: none"> Partial water change Add macro algae Feed sparingly Reduce number of fish
Cu Copper Fresh water Fish feeling unwell	ideal: 0.0 mg/l (ppm) (every detectable amount severely harms invertebrates or is fatal to them) above 1.0 mg/l (ppm): fatal for all living beings in marine aquariums	<ul style="list-style-type: none"> Add sera aquatan Generous partial water changes with copper-free water, prepare fresh water with a double dose sera aquatan
O ₂ Oxygen every 2 weeks	above 6 mg/l (ppm): sufficient oxygen	<ul style="list-style-type: none"> Rapid increase with sera O₂ plus Aerate water
Cl Chlorine Water change New setup	below 0.02 mg/l (ppm)	<ul style="list-style-type: none"> Find out and remove cause sera aquatan neutralizes the effects of chlorine Add sera marin bio reefclear Aerate water well





9.7 Cleaning the filter media

Mechanical filter media are washed out once weekly. As coarse particles are collected by the mechanical filter media (sponges), it is sufficient to wash out the biological filter medium **sera siporax** only every 3 to 6 months. Be sure to use marine water from a water change for this pur-

pose. The filter media are washed out in the removed marine water until no cloudiness is released any more. The water missing now is replenished with freshly prepared and matured marine water. Adding **sera marin bio reef-clear** compensates the loss of nitrifying bacteria during the water change.

9.8 Removing excess algae

If macro algae, such as *Caulerpa*, grow in your aquarium, you should carefully control their growth. The rapidly growing *Caulerpa* algae can actually overgrow invertebrates. Be careful when removing such algae, and do not remove too much algae at one time.

The algae “leaves” are so-called “thalli”. They consist of a single cell that will release its nitrate-containing cell liquid into the aquarium if it is not removed

properly. We recommend to proceed as follows:

The rhizome (this is the cord from which the single thalli grow) has fragile spots beside the thalli where you can carefully break the algae apart. Immediately remove the unwanted part of the *Caulerpa* algae from the aquarium. Be careful not to damage the algae, as this will lead to cell liquid running into the aquarium uncontrollably.

9.9 Removing deposits

Waste (e.g. dead algae parts) accumulating between water changes must be removed instantly, e.g. by

means of the **sera gravel cleaner**. Waste that is not removed will cause severe water pollution.

9.10 Testing the lighting

The fluorescent tubes should be replaced with new ones after a year at

the latest. The human eye does not detect the gradual reduction of light emittance.

10. When you are on a vacation

It depends on the fish species whether the fish need to be fed every day. Small, bottom orientated fish such as gobies tolerate a couple of days without being fed. They will find enough food between the live rock chunks or in the plant periphyton. However, bigger, freely swimming fish consume more energy while swimming and therefore must be fed regularly.



We recommend setting up a maintenance plan for your vacation replacement in case of a longer vacation. It should include the regular addition of trace elements, calcium and macro elements (from page 42) for the invertebrates and topping up evaporated water against strong density variations.

Prepare daily portions for feeding. If you have the opportunity to use an automatic feeder, the **sera feed A plus** allows you to feed up to 30 days, depending on the number of fish. **sera marin granules** is excellently suited for automatic feeders. The soft granulate keeps its shape and floats in the water long enough to be entirely eaten by the fish. The valuable ingredients are optimally digested, thus avoiding unnecessary water pollution.

Give your fish an extra portion **sera fish-tamin** before your holiday. By doing so, your fish will remain fit, healthy and lively.

11. What to do in case an animal gets ill

Invertebrates

Good maintenance provided, invertebrate diseases rarely occur. You should nevertheless consider certain precautions.

The skeleton formation of stony corals is affected if the water temperature exceeds 30°C (86°F). Furthermore, the symbiotic algae living in the coral tissues (zooxanthellae) die, and consequently also the coral itself will die.

Crustaceans shed their skin regularly. The water must contain approximately 400 – 450 mg/l (ppm) calcium for them to build up a new exoskeleton; the carbonate hardness must be between 8 – 10°dKH.

If an invertebrate becomes stunted despite best possible maintenance conditions, the animal must be examined for external parasites. Those parasites may be very small and possibly only come out at night. The animals should be fed **sera crabs natural** and **sera shrimps natural** as to prevent deformations while shedding their skin.

Planarians are flat white or red worms sized approximately 5 mm. They can harm anemones, corals, etc., with their excreted slime. The worms can be siphoned out of the aquarium by means of a flexible hose. Sometimes it is useful to place a strong torch above the aquarium at night, since many planarians assemble in the light and then are easier to remove. Check invertebrates thoroughly before buying them! Small, brownish-red, oval spots are usually planarians.

Although **bristle worms (Polychaetes)** are actually debris eaters, they eventually nibble on mushroom anemones and stony corals. Furthermore, they tear at their prey and injure the animal with their sharp jaws. It is possible to attract them with fish meat, then catch and remove them. As they are mainly active at night, this procedure should be carried out in the dark. Be careful: Do not touch these



worms. The bristles break off and may cause skin inflammations!

Small bristle worms hide in the gravel during daytime and can be removed by siphoning off a large quantity of the substrate (approximately 30 – 50%) and washing it with fresh water. Usually, this is sufficient to remove bristle worms from time to time.

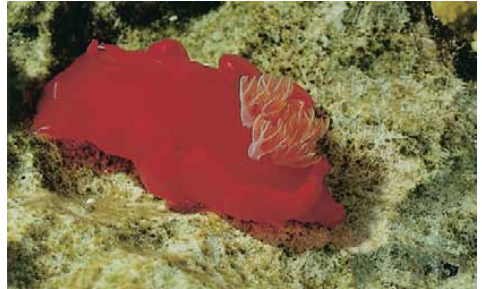

Many **snails** nibble on sea anemones, corals, etc. In a reef aquarium, every snail should be carefully removed by means of a pair of tweezers. Some snails exclusively feed on sessile invertebrates.



Predatory shrimp species, such as **marbled shrimps** (different *Saron* species), can literally cut up anemones. When interested in these nocturnal animals, they must be kept separate.

Parasitic diseases caused by micro organisms (bacteria, single celled parasites) virtually only occur after preliminary damage caused by chemicals (e.g., ozone, hydrogen peroxide, phosphate) and are almost never observed in well maintained aquariums.

Combating the mentioned parasites with remedies is only possible in a quarantine tank because remedies cannot differentiate between „desired“ and „undesired“ invertebrates.

Fish

Diseases affecting ornamental fish are reliably treated with **sera treatments**. The danger of a disease outbreak is reduced by proper maintenance and regular vitamin supply with **sera fishtamin**. We recommend dripping **sera fishtamin** onto the food and then allowing it to soak in for a minute immediately before feeding.

The most frequent and disturbing disease that affect marine fish – and the recommended care for your fish while ill, are described below.



An *Oodinium ocellatum* (velvet disease) infection is effectively treated with **sera med Professional Protazol**. Please read the instructions for use carefully.

The ciliate *Cryptocaryon irritans* resembles the freshwater parasites *Ichthyophthirius* and is therefore also called “Marine water Ich”. Its symptoms are white spots of up to 1 millimeter in diameter and strong scrubbing movements of the fish.



Cryptocaryon is treated with **sera costapur** or **sera med Professional Protazol**. **sera costapur** is harmful for some invertebrates (e.g. stony corals, snails, shrimps) and must only be used in a quarantine tank for safety reasons.





Bacterial diseases cause various symptoms. The most important symptoms include skin slime and fin rot. Bacterial diseases are treated in a quarantine tank with **sera baktopur** and **sera baktopur direct** according to the instructions.

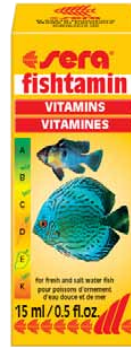

sera med Professional treatments – High effective and well tolerated

In close cooperation with the working group of the well known parasitologist, Prof. Dr. Heinz Mehlhorn (Heinrich-Heine-Universität Düsseldorf/Germany), **sera** succeeded in marketing a range of unique, highly effective over the counter treatments. The products mainly appeal to versed, experienced users who look for quick and specific support from highly effective treatments after having diagnosed a specific disease.

sera med Professional Tremazol contains the reliably and directly effective Praziquantel, which has been successfully used against flatworm infections in human and veterinarian medicine for a long time. The patented, highly effective agent dissolving complex ensures even distribution of the otherwise poorly soluble substance in water, making the active agent get to the pathogen very quickly.

The effect spectrum of the treatment ranges from gill and skin flukes (*Dactylogyrus* sp., *Gyrodactylus* sp.) to tapeworms (e.g. *Bothriocephalus* sp.). Besides its excellent efficacy it is also very well tolerated and is suited for treating marine fish in a quarantine tank.



After the treatment

You should always carry out treatments in a quarantine tank since many invertebrates do not tolerate treatments.

Fish are considerably weakened by a disease. A vitamin treatment with **sera fishtamin** should be carried out for strengthening the fish after a disease treatment. We recommend dripping **sera fishtamin** onto the food and then allowing it to soak in for a minute immediately before feeding.

Using treatments may also affect useful bacteria. **sera marin bio reefclear** should therefore, be used according to the information for use after every treatment. **sera super carbon** will remove treatment remainders from the water after the treatment.

Cleaner wrasses and cleaner shrimps help remove ectoparasites. Some stinging coral species (e.g., gorgonians) also help protect fish against some diseases.

You will find detailed information about recognizing and treating fish diseases in the **sera guide** “Healthy aquarium fish”.

Good, constant water conditions and a varied nutrition as well as an appropriate vitamin supply are the most important prevention against fish diseases.

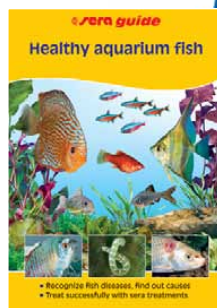



40/11US

sera GmbH • D 52518 Heinsberg • Germany



For natural aquariums

www.sera.de • info@sera.de